

# USB Front Cable (CA5-USBEXT-01) Installation Guide

Thank you for purchasing Pro-face's USB Front Cable (hereafter referred to as the "cable"). This manual describes suggestions for extending a USB Host Interface of Pro-face's Display(Unit). Prior to using this cable, please be sure to read this manual completely and use it properly following the descriptions.

Please confirm that the following items are included in the cable's package.

- Installation Guide (This manual)
- A USB Front Cable (length: 1m [39.37in.])
- A waterproof cap
- A nut
- A packing

## Safety Precautions

### WARNINGS

- Prior to connecting the cable, check that the Display's power supply is completely turned OFF to prevent an electric shock.
- Do not modify the cable, since it may lead to a fire or electric shock.
- This cable is not appropriate for use with aircraft control devices, aerospace equipment, central trunk data transmission (communication) devices, nuclear power control devices, or medical life support equipment, due to these devices inherent requirements of extremely high levels of safety and reliability.
- When using this cable with transportation vehicles (trains, cars and ships), disaster and crime prevention devices, various types of safety equipment, non-life support related medical devices, etc. redundant and/or failsafe system designs should be used to ensure the proper degree of reliability and safety.
- When this unit is disposed of, it should be done so according to your country's regulations for similar types of industrial waste.

# Dimensions

Unit:mm[in.]

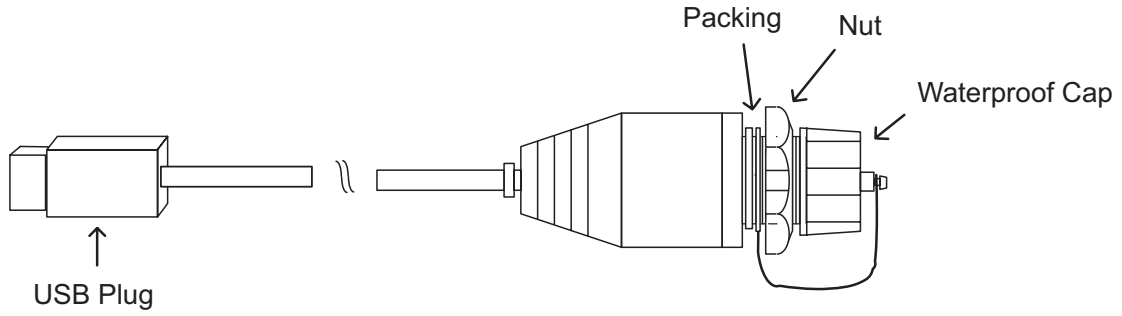

Packing

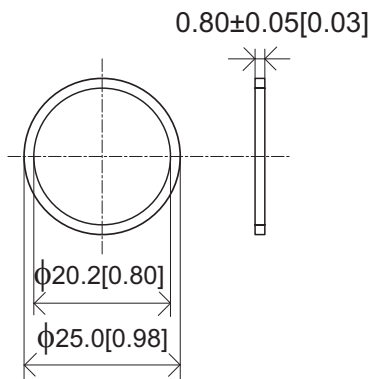

Nut

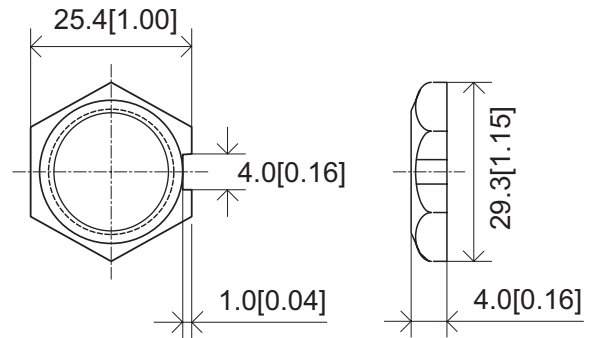

Waterproof Cap

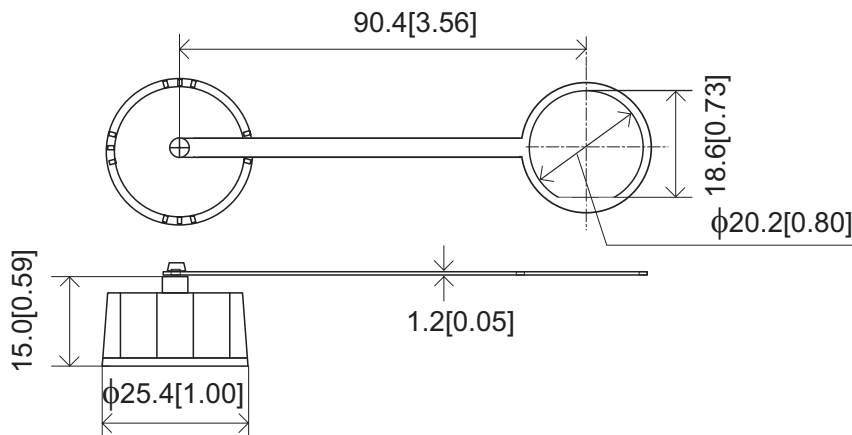

USB Front Cable

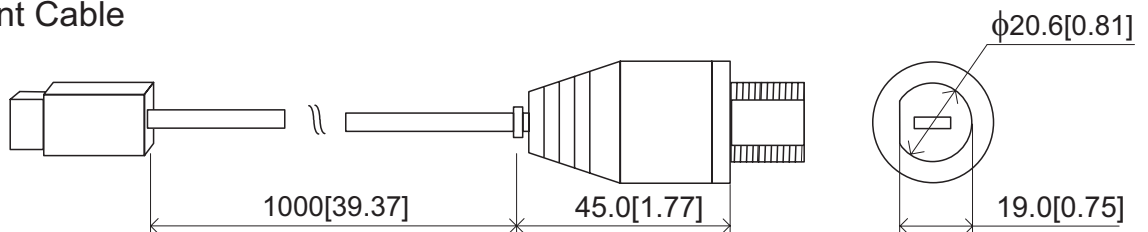

# Installation

The USB plug side of a cable is attached in Display. Attach the packing, the cap (the packing part), the nut, and the cap (the main part) carefully as shown below with confirming that they are not bent or twisted.

Unit:mm[in.]

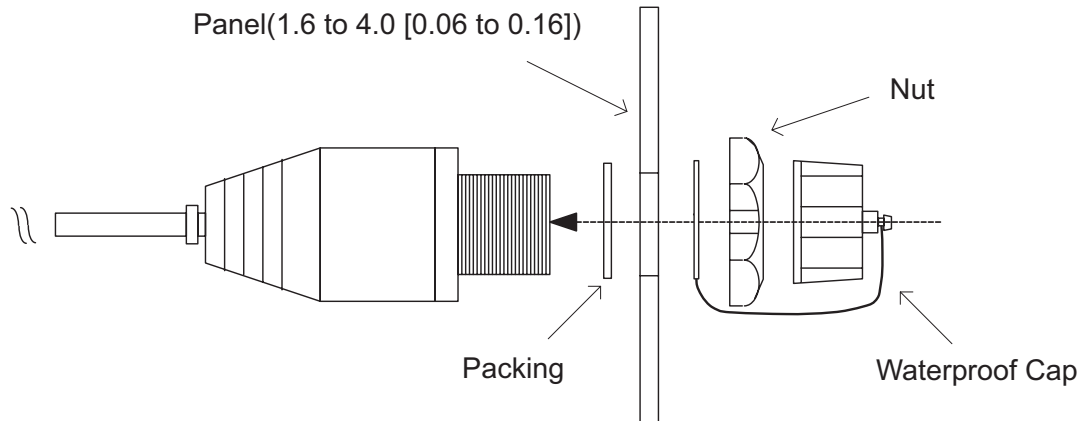

- ***If the cap is attached to this cable, IP65f will be applied to the front side (the right side of the panel in the figures above) only.***
- ***Tighten the cap. Tighten the nut with the torque (0.1N•m). If the torque is too strong or weak, efficiency of waterproof may not be fully made.***

# Panel Cut Dimensions

Please adopt the figure on the left side in the figures shown above. If the figure on the right side is adopted, efficiency of waterproof might be reduced.

Unit:mm[in.]

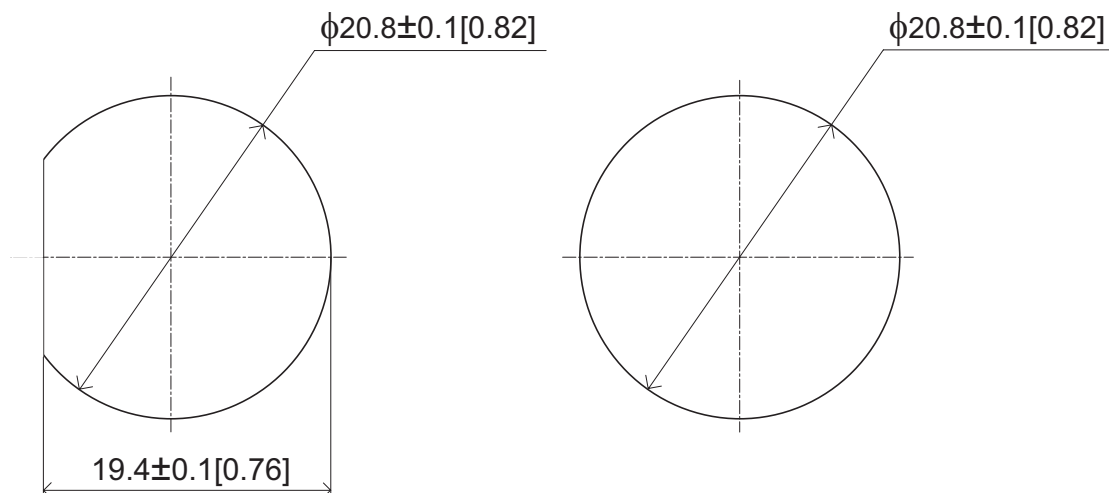

**Note**

Please be aware that Digital Electronics Corporation shall not be held liable by the user for any damages, losses, or third party claims arising from the uses of this product.